

JOB \_\_\_\_\_ ITEM # \_\_\_\_\_ QTY # \_\_\_\_\_



RP-16



**PIPER'S SUPERIOR FOUNDATION**

Fully welded coated steel frame with 18 gauge base plate

Maximize proofing capacity while saving valuable floor space with the RP-16. This self-contained proofer provides efficient, consistent proofing. Our dependable controls and standard automatic humidity take the worry and hassle out of the proofing process.

**STANDARD FEATURES**

- ◆ Individual heat and humidity controls provides precise control over proofing environment
- ◆ Individual heat controls go from 0° to 125° (optional 225°)
- ◆ High volume blowers Circulates heat and humidity efficiently
- ◆ Standard automatic humidity Eliminates manual fill water pan
- ◆ Full-view glass door provides sight-proofing
- ◆ Heavy-duty cabinet construction and stainless steel finish - interior and exterior - provides long life and easy maintenance

**MODEL NUMBER**

- RP-16
- RP-16-W

**DIMENSIONS**

- ◆ 70"H x 33"W x 36"D
- ◆ 40" Depth including handle

**CONSTRUCTION**

The proofer's interior and exterior shall be constructed of 20 gauge stainless steel. Corner posts constructed of 18 gauge stainless steel. The proofer shall have two thermostatically controlled 750 watt elements for creating heat and an infinitely controlled humidistat 1250 watt burner element for creating moisture. Proofer shall be brightly lit providing sight merchandising.

Proofer shall have two individual circuit breakers. One for the proofer thermostat and heat element. One for the humidity infinite switch and burner element and the proofer lights.

**WARMER OPTION**

- ◆ Fully insulated
- ◆ Holds maximum temperature of 225°
- ◆ Maintains back-up product for display
- ◆ Separate humidity control keeps product at ideal moisture level for peak flavor

**COMMON OPTIONS**

- ◆ Manual-fill water pan is available

**WARRANTY**

- ◆ One year parts and labor. Warranty is detailed on inside front cover of the price list.

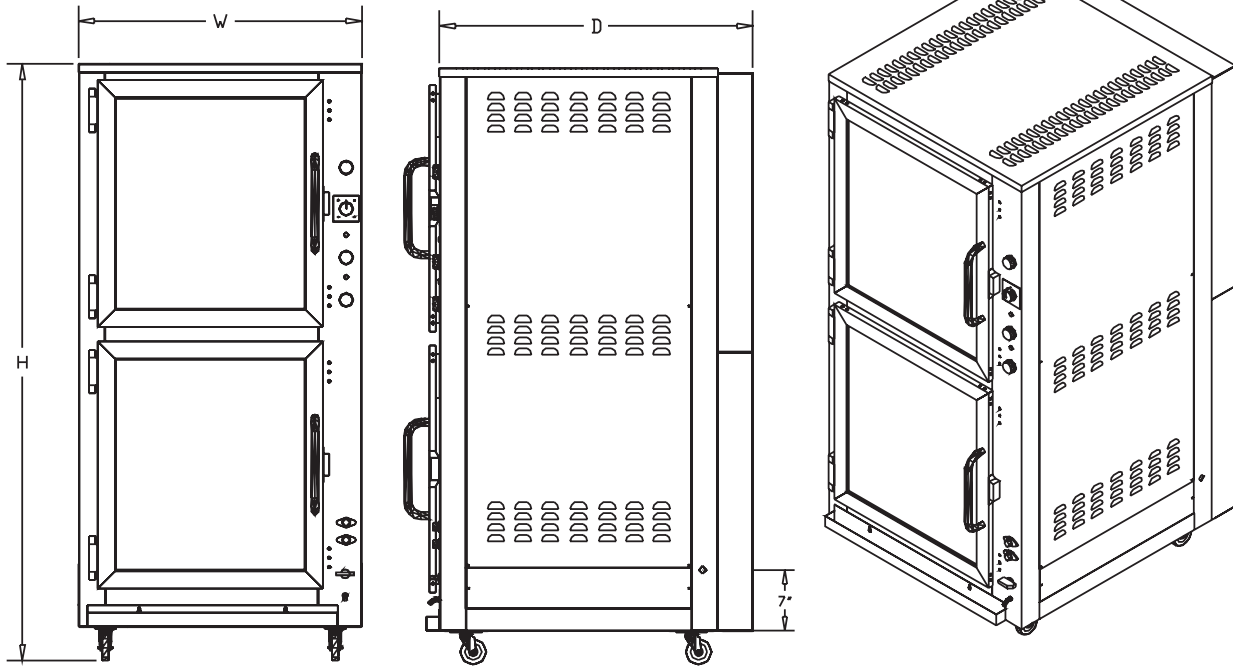

Interior Dimensions: 57"H x 24-1/2"W x 30"D Racks are adjustable every 3 inches.

Please specify doors hinged left or right. Hinged left is standard.

**ELECTRICAL\***

Volts	Phase	Wire**	Amps	Watts	Hertz
120	1	2	19	2253.5	60
120/208	1	3	13	2253.5	60
120/208	3	4	n/a	2253.5	60
120/240	1	3	11	2253.5	60
120/240	3	4	n/a	2250.5	60

Unit is also available in 120/208 and 120/240. Consult factory for details.

\*Units are shipped without cord and plug. Designed to be hard wired.

Installation requires a 4" clearance around the entire unit and should be made by a licensed electrician. Check local codes for vent hood requirements.

\*\* Number of wires does not include ground.

Note: Automatic humidity feature, standard with the proofer section, requires 1/8" FPT water line to be supplied. Product failure caused by liming or sediment buildup is not covered under warranty.

**OPTIONS / ACCESSORIES**

- Additional proofer racks
- Manual-fill water pan (in lieu of automatic humidity)
- Warmer option (fully insulated) (RP-16-W)

**CAPACITY**

- ◆ Accommodates 16 nylon-coated wire racks (12 furnished with unit)
- ◆ 16 standard 18" x 26" sheet pans
- ◆ 16 donut screens (of various sizes)
- ◆ 16 four-strapped 1 lb. bread pans
- ◆ 8 four-strapped 1.5 lb. bread pans
- ◆ Additional racks are available.

Please see accessories list for more detail.

**SHIPPING INFORMATION**

- ◆ Shipping weight: 500 lbs.
- ◆ Cubic feet: 51.91
- ◆ Freight class: 100
- ◆ Crated dimension: 74H x 37.5W x 45D

**Q-2 SPEC**

**PIPER PRODUCTS**  
**BUILT TO LAST**  
[www.piperonline.net](http://www.piperonline.net)

300 S. 84th Avenue  
 Wausau, WI 54401  
 Phone: 800-544-3057  
 Fax: 715-842-3125

**LIMITED WARRANTY:** PIPER PRODUCTS warrants to the original purchaser parts and labor for a period of twelve (12) months from the date of purchase. See manufacturer's complete warranty for details.

It is our policy to build equipment which is design certified by companies that have been accredited at the Federal Level by the Occupational Safety and Health Agency (OSHA) and ANSI as a National Recognized Testing Laboratory. These companies include CSA International, Underwriters Laboratories, and the National Sanitation Foundation. However, a continuing program of product improvement makes it necessary to submit new models to the agencies as they are developed. Consequently, all models may not bear the appropriate labels at all times.

We reserve the right to change specifications and product design without notice. Such revisions do not entitle buyer to corresponding changes, improvements, additions or replacements for previously purchased equipment. Information is not for design purposes.