

JOB \_\_\_\_\_ ITEM # \_\_\_\_\_ QTY # \_\_\_\_\_

**MODEL NUMBER**

- |                                 |                                  |                                    |
|---------------------------------|----------------------------------|------------------------------------|
| <input type="checkbox"/> CS2-5  | <input type="checkbox"/> CS2-5SL | <input type="checkbox"/> CS2-5/5   |
| <input type="checkbox"/> CS2-5L | <input type="checkbox"/> CS2-10  | <input type="checkbox"/> CS2-5S/5S |
| <input type="checkbox"/> CS2-5S | <input type="checkbox"/> CS2-10S | <input type="checkbox"/> CS2-5S/5  |

**DIMENSIONS**

- ◆ All Models: 26 1/4"W x 34 7/8"D
- ◆ 5-Pan: 34" H with 4" standard casters
- ◆ 10-Pan: 52-1/4" H with 4" standard casters
- ◆ Stacking 5-pan: 65-5/8" H with 4" standard casters
- ◆ Add 1" for units with 5" casters. Deduct 2" for units with 2" low profile casters.

**CABINET OPENING**

- ◆ 5-Pan: 18 1/4"W x 20 1/2"H
- ◆ 10-Pan: 18 1/4"W x 38 1/2"H

**SMOKER STANDARD FEATURES**

**(CS2-5S, CS2-5SL, CS2-5S/5S, CS2-5S/5, CS2-10S)**

- ◆ 350° (177°C) Thermostat
- ◆ Individually controlled, on/off switch, touchpad controls and indicator lights.
- ◆ Two extra controls allow you to set the smoker delay and timer.
- ◆ The smoker box heats pieces of real wood wet or dry.

**WARRANTY**

- ◆ One year parts and labor. Warranty is detailed on inside front cover of the price list.



CS2-5

CS2-10S

The Chef System Cook & Hold Oven roasts meat, poultry and fish, to juicy tenderness... and holds the flavor until ready to serve. Featuring an exclusive Roast-Air™ process, Chef System uses radiant and convection heat that browns naturally, tenderizes and holds natural juices, creating distinctive and tasteful entrees.

**ALL MODELS - STANDARD FEATURES**

- ◆ Product probe for precise, consistent results. Meat probe comes standard.
- ◆ Far less shrinkage – meats cooked in the Chef System shrink as little as 7-10% compared to 25% in conventional ovens. The savings mean greater profitability.
- ◆ Exclusive Roast-Air cooking process combines 90% radiant heat with 10% low velocity convection to brown food naturally.
- ◆ Easy-to-use controls combine digital precision with simple touchpad adjustments. The settings can be changed at any time during the cooking process – preheating, cooking or holding.
- ◆ External vents control humidity without losing heat from opening the oven door.
- ◆ Power interruption warning – if power is ever lost for more than 10 minutes, the display will indicate the total power interruption time.
- ◆ Cleaning made easy – Chef System’s stainless steel interior walls, drip pan and wire racks are easily removed for cleaning in a pot and pan sink.
- ◆ The drip tray ensures a cleaner work environment.
- ◆ Versatility – slow roast and hold, smoke and hold or bake with Chef System ovens.

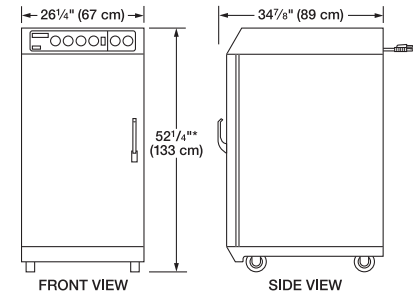
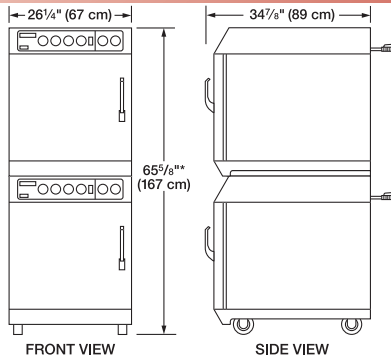
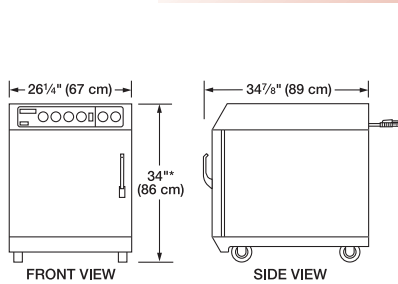

## 5 PAN MODELS

Model*	Watts	Product Capacity	Shipping Weight =
Cook & Hold Ovens			
CS2-5	2170	90 lbs.	265 lbs.
CS2-5L	1795	90 lbs.	265 lbs.
Smoke & Hold Ovens			
CS2-5S	2320	90 lbs.	265 lbs.
CS2-5SL	1945	90 lbs.	265 lbs.

\* "L" indicates 120 volt models only. All other models are available in 208, 220 and 240 volts.

## 10 PAN MODELS

Model*	Watts	Product Capacity	Shipping Weight=
Cook & Hold Oven			
CS2-10	2870	180 lbs.	360 lbs.
Smoke & Hold Oven			
CS2-10S	3020	180 lbs.	360 lbs.

= Add 90 lbs. (41 kg) for crates when shipping outside U.S.

## 5-PAN MODELS

Model	60 Hz			50 Hz	
	120V	208V	240V	220V	240V
CS2-5	-	6-15P	6-15P	CEE 7/7 Schuko	BS-1363
CS2-5L	5-15P, 5-20P†	-	-	-	-
CS2-5S	-	6-15P	6-15P	CEE 7/7 Schuko	BS-1363
CS2-5SL	5-20P, 5-30P†	-	-	-	-

## 10 PAN MODELS

Model	60 Hz		50 Hz	
	208V	240V	220V	240V
CS2-10	6-15P, 6-20P†	6-15P	CEE 7/7 Schuko	BS-1363
CS2-10S	6-15P, 6-20P†	6-15P	CEE 7/7 Schuko	BS-1363

† For Canada

L-1 SPEC

**PIPER PRODUCTS**  
 BUILT TO LAST  
[www.piperonline.net](http://www.piperonline.net)

300 S. 84th Avenue  
 Wausau, WI 54401  
 Phone: 800-544-3057  
 Fax: 715-842-3125

## 5 PAN MODELS STACKED

Model^	Watts	Product Capacity	Shipping Weight =
Cook & Hold Ovens			
CS2-5/5	2170 ea.	180 lbs.	530 lbs.
Smoke & Hold Ovens			
CS2-5S/5S	2320 ea.	180 lbs.	530 lbs.
Smoke/Cook & Hold Ovens			
CS2-5S/5	2320/2170	180 lbs.	530 lbs.

^ Other combinations available, consult factory.

All models standard with a 250°F (121°C) maximum temperature. 350°F (177°C) models available for 208, 220 and 240 volt

Non-smoker units, consult factory. 5-Pan models include 6 removable side racks. 10-Pan models include 10 removable side racks. (Quantities for export models vary, consult factory.)

## OPTIONS / ACCESSORIES (NOT FOR RETROFIT)

- 350°F (177°C) Thermostat (Non-Smoker Models)
- Bumper Guards
- Security Package (Locking Control Panel Cover)

## ACCESSORIES

- Stainless Steel Legs
- Heavy-Duty 5" Diameter Casters
- Stacking Hardware
- Low Profile 2" Casters
- 18" x 26" Sheet Pans
- Rib Rack Stainless Steel (13 Slots)
- Wire Side Racks
- 20 Amp Receptacle, 125V (NEMA 5-20R)
- 20 Amp Receptacle, 250V (NEMA 6-20R)

**LIMITED WARRANTY:** PIPER PRODUCTS warrants to the original purchaser parts and labor for a period of twelve (12) months from the date of purchase. See manufacturer's complete warranty for details.

It is our policy to build equipment which is design certified by companies that have been accredited at the Federal Level by the Occupational Safety and Health Agency (OSHA) and ANSI as a National Recognized Testing Laboratory. These companies include CSA International, Underwriters Laboratories, and the National Sanitation Foundation. However, a continuing program of product improvement makes it necessary to submit new models to the agencies as they are developed. Consequently, all models may not bear the appropriate labels at all times.

We reserve the right to change specifications and product design without notice. Such revisions do not entitle buyer to corresponding changes, improvements, additions or replacements for previously purchased equipment. Information is not for design purposes.