

JOB \_\_\_\_\_ ITEM # \_\_\_\_\_ QTY # \_\_\_\_\_

**MODEL NUMBER**

- CS2H-5                       CS2H-5/5
- CS2H-10



CS2H-5

Improve holding capabilities with the Chef System Humidified Holding Cabinets! Designed for simple operation and exceptional holding performance in 5- or 10-pan models, the CS2H provides Piper reliability in a holding cabinet that keeps a wide range of menu items hot for extended holding times.

With 5 levels of humidity, crisp food will stay crisp and moist food moist. The 90°F to 185° (32°C to 85°C) air temperature range allows precise food temperature control for holding and proofing.

**STANDARD FEATURES**

- ◆ Precise temperature and humidity control is ideal for proofing and for holding.
- ◆ Prepare food in advance of peak serving periods.
- ◆ Five levels of humidity to keep crisp food crisp and moist food moist.

**DIMENSIONS**

- ◆ CS2H-5: 26-7/8"W x 34"D† x 34"H on 4" casters.
- ◆ CS2H-10: 26-7/8"W x 34"D† x 51-1/2"H on 4" casters.
- ◆ †Add 1 1/4" for pass-through models.

**FEATURES**

- ◆ Temperature Range: 90°F to 185°F (32°C to 85°C)
- ◆ Relative Humidity Settings:
  - 1 = 20%,
  - 2 = 35%,
  - 3 = 50%,
  - 4 = 65%,
  - 5 = 80%
- ◆ Water Capacity: 2.5 gallons

**ELECTRICAL**

- ◆ 120 volts, 60 Hz, 2350 watts, 19.6 amps (uses NEMA 5-20P). (Not available in Canada.)
- ◆ 208 volts, 60 Hz, 2350 watts, 11.3 amps (uses NEMA 6-15P).
- ◆ 240 volts, 60 Hz, 2350 watts, 9.8 amps (uses NEMA 6-15P).

**WARRANTY**

- ◆ One year parts and labor. Warranty is detailed on inside front cover of the price list.



CS2H-10

**SPEC K-4**

**PIPER PRODUCTS**  
 BUILT TO LAST  
[www.piperonline.net](http://www.piperonline.net)

300 S. 84th Avenue  
 Wausau, WI 54401  
 Phone: 800-544-3057  
 Fax: 715-842-3125

## MODEL # CS2-5

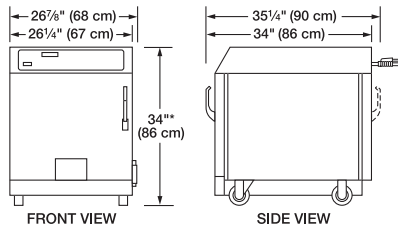

Shown with pass thru option

## MODEL # CS2H-5/5

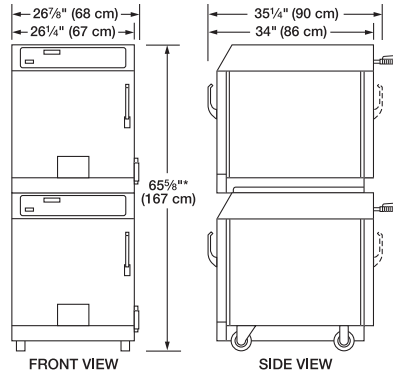

Shown with pass thru option

## MODEL # CS2H-10

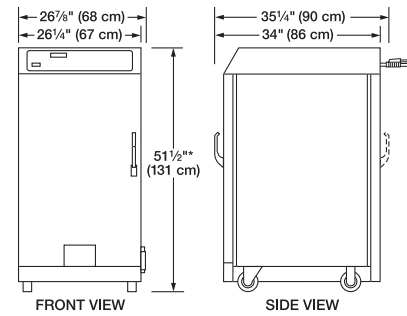

Shown with pass thru option

## SPECIFICATIONS

Model	Rack Style*	Shipping Weight
CS2H-5	Adjustable Slides	240 lbs.
CS2H-10	Adjustable Slides	320 lbs.
CS2H-5/5	Adjustable Slides	480 lbs.

- 5-Pan Model has 5 slides on each side. Sheet Pans not included.
- 10-Pan Model has 10 slides on each side. Sheet Pans not included.

Typical freight class: 85

## CAPACITY

		No. of 2 1/2" (6 cm) Deep Pans	No. of 1" (3 cm) Deep Pans
CS2H-5	3 3/4" Centers	10 (2 per shelf)	5
	2 1/2" Centers	—	7 (Extra slides required)
CS2H-10	3 3/4" Centers	20 (2 per shelf)	10
	2 1/2" Centers	—	14 (Extra slides required)

Part Number	Description
<input type="checkbox"/> CS2H-SSBack-5	Stainless Steel Back in lieu of powder coating (CS2H-5 only)
<input type="checkbox"/> CS2H-SSBack-10	Stainless Steel Back in lieu of powder coating (CS2H-10 only)
<input type="checkbox"/> CS2H-Heavycast	5" Heavy-Duty Casters (In lieu of standard Casters)
<input type="checkbox"/> CS2H-SSLeg	6" Stainless Steel Adjustable Legs (In lieu of standard Casters)
<input type="checkbox"/> CS2H-Stack	Stacking hardware for multiple holding cabinets
<input type="checkbox"/> CS2H-Slide	Additional slides
<input type="checkbox"/> 20A-Recep	20 Amp receptacle, 125V (Nema 5-20R)
<input type="checkbox"/> PT	Passthru

## WATER QUALITY REQUIREMENTS

Water supply in excess of 3.0 grains of hardness per gallon (GPG) must be treated and softened before being used. Water containing over 3.0 GPG will decrease the efficiency and reduce the operating life of the unit.

Note: Product failure caused by liming or sediment buildup is not covered under warranty.

## CORD LOCATION

Rear top center.

Pass-through models: Rear top, left-hand side.

## PLUG CONFIGURATIONS

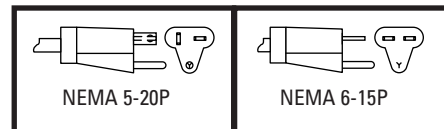

**LIMITED WARRANTY:** PIPER PRODUCTS warrants to the original purchaser parts and labor for a period of twelve (12) months from the date of purchase. See manufacturer's complete warranty for details.

It is our policy to build equipment which is design certified by companies that have been accredited at the Federal Level by the Occupational Safety and Health Agency (OSHA) and ANSI as a National Recognized Testing Laboratory. These companies include CSA International, Underwriters Laboratories, and the National Sanitation Foundation. However, a continuing program of product improvement makes it necessary to submit new models to the agencies as they are developed. Consequently, all models may not bear the appropriate labels at all times.

We reserve the right to change specifications and product design without notice. Such revisions do not entitle buyer to corresponding changes, improvements, additions or replacements for previously purchased equipment. Information is not for design purposes.