

JOB \_\_\_\_\_ ITEM # \_\_\_\_\_ QTY # \_\_\_\_\_

**MODEL NUMBER**

- ER-18-L
- ER-18-R

**DIMENSIONS**

- ◆ 70-1/4"H x 21-1/2"W x 28-3/4"D

**CAPACITY**

- ◆ Eighteen, 18" x 26" sheet pans
- ◆ Thirty-six, 14" x 18" sheet pans

**CONSTRUCTION**

The cabinet frame shall be constructed of 1"x 1", .063, square tube aluminum. The cabinet wrapper shall be .063 PVC coated aluminum. There shall be four removable interior side racks constructed of aluminum tubing with .063, 1" x 1.5" angle glides welded on 3.25" spacing. Cabinet doors shall be constructed of clear coat anodized aluminum extrusion with lexan inserts. Cabinet shall have two separate compartments with removable doors and magnetic enclosures. Top compartment shall be vented.

**HEAVY-DUTY CASTERS**

- ◆ 5" x 1-1/4" sealed wheel stem casters
- ◆ 350 lbs. capacity
- ◆ Maximum resistance to chemicals, acids, bases, alcohol, water and steam
- ◆ Maximum low temperature flexibility for superior performance, even in freezing temperatures

**WARRANTY**

- ◆ One year parts and labor. Warranty is detailed on inside front cover of the price list.



Piper's Enclosed Rack offers a cooling rack for product coming out of the oven while providing merchandising to display product. Removable doors and tray glides allow for easy cleaning and maintenance.

**STANDARD FEATURES**

- ◆ Includes wider spacing between glides to eliminate possibility of slicing tops of rolls when sliding pans in and out - 3-1/4" spacing
- ◆ Units will hold 18 of the 18" x 26" standard sheet pans or 36 of the 18" x 13" half size sheet pans
- ◆ Side glides and bottom are removable for ease of cleaning, simply lift up and out
- ◆ Magnetic closure adjustable for tight fitting door
- ◆ Sturdy framed doors provide strength and attractive clarity
- ◆ Adjustable vent at top of unit to relieve excess heat
- ◆ Four 5" heavy-duty non-marking swivel casters, front include brakes
- ◆ Removable doors lift off for easy access during busy times

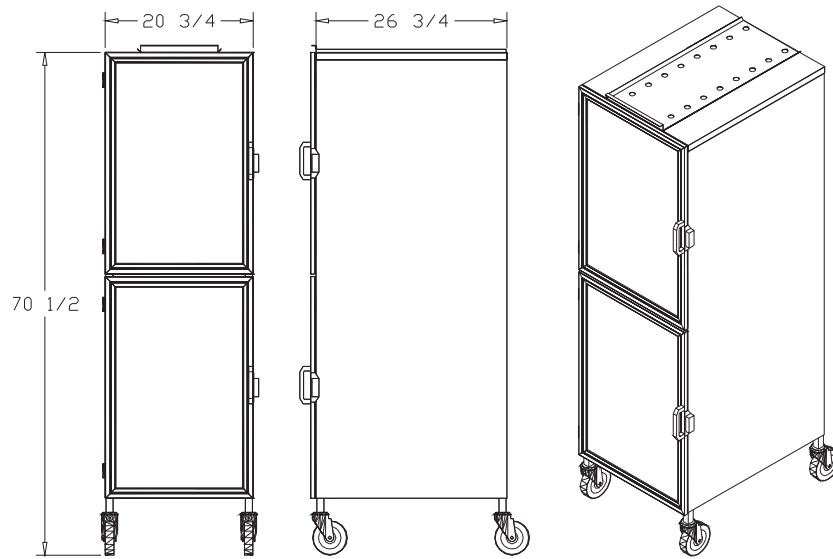

Adjustable vent on top of unit vents heat and moisture

The Piper ER-18 Enclosed Rack is designed to provide an attractive storage cabinet.

	Height	Width	Depth	Door Width
Exterior Dimensions	70-1/4"	21-1/2"	28-3/4"	20-3/4"
Interior Dimensions	61-1/2"	18-1/2"	24-1/2"	

- 3-1/4" spacing between glides
- Capacity is 18 standard 18" x 26" sheet pans
- Specify door hinge right or left.
- Shipping weight approximately 140 lbs.
- Shipping class: 125



Interior racks are easily removed for cleaning and maintenance

**J-2** SPEC

**PIPER PRODUCTS**  
BUILT TO LAST  
[www.piperonline.net](http://www.piperonline.net)

300 S. 84th Avenue  
Wausau, WI 54401  
Phone: 800-544-3057  
Fax: 715-842-3125

**LIMITED WARRANTY:** PIPER PRODUCTS warrants to the original purchaser parts and labor for a period of twelve (12) months from the date of purchase. See manufacturer's complete warranty for details.

It is our policy to build equipment which is design certified by companies that have been accredited at the Federal Level by the Occupational Safety and Health Agency (OSHA) and ANSI as a National Recognized Testing Laboratory. These companies include CSA International, Underwriters Laboratories, and the National Sanitation Foundation. However, a continuing program of product improvement makes it necessary to submit new models to the agencies as they are developed. Consequently, all models may not bear the appropriate labels at all times.

We reserve the right to change specifications and product design without notice. Such revisions do not entitle buyer to corresponding changes, improvements, additions or replacements for previously purchased equipment. Information is not for design purposes.