

JOB _____ ITEM # _____ QTY # _____

MODEL NUMBER

- CSC-4
- CSC-5
- CSC-6
- CSC-7
- CSC-8

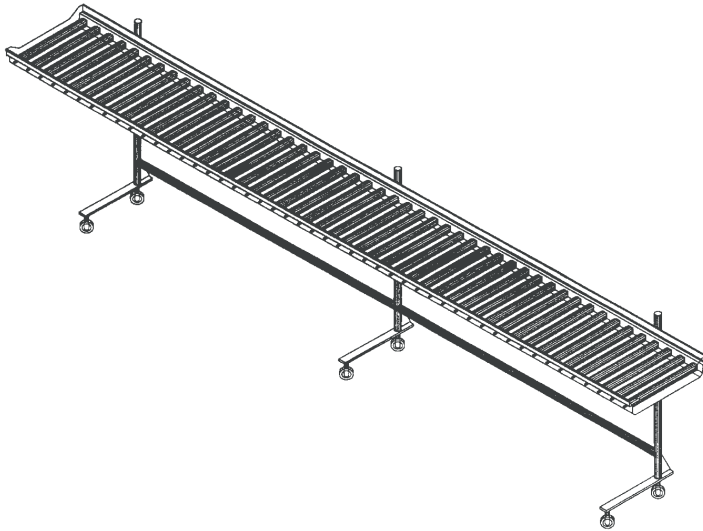

The Cantilever conveyor can be positioned under support equipment with conveyor roller assembly over top of the support equipment. There are two different styles of cantilever conveyor. The roller has 1.7/8" PVC rollers making it ideal for compartmental trays as well as flat bottom trays. The skate wheel has 2" diameter nylon wheels and will handle flat bottom trays only. The cantilever conveyors can be a space saver in certain applications.

STANDARD FEATURES

- ◆ 3" diameter swivel plate type casters (2 of 4 or 3 of 6 have brakes)
- ◆ Adjustable height
- ◆ Stainless steel frame
- ◆ Stainless steel uprights
- ◆ PVC rollers or Nylon skate wheels

CONSTRUCTION

The cantilever conveyor has a standard conveyor pan. The roller style shall have 1-7/8" O.D. gray PVC tubing with stainless steel hex spring-loaded shafts. The skate wheel style shall have 2" diameter nylon wheels with low friction bushing for free movement. Wheels are secured to frame with stainless steel bolts with self locking nuts. Wheels are spaced on 3" to 4" centers and are removable for easy cleaning.

Cantilever conveyor uprights are 1-5/8" diameter 16-gauge stainless steel tube. Conveyors up to 6' have two uprights. Uprights have 1-1/4" 18-gauge stainless steel cross rails welded between for support and each upright has a 12-gauge stainless steel fully welded gusset for support.

Pan consists of a 14-gauge stainless gusset welded to a stainless tube that slides over uprights making an adjustable conveyor height.

WARRANTY

One year parts and labor. Warranty is detailed on inside front cover of the price list.

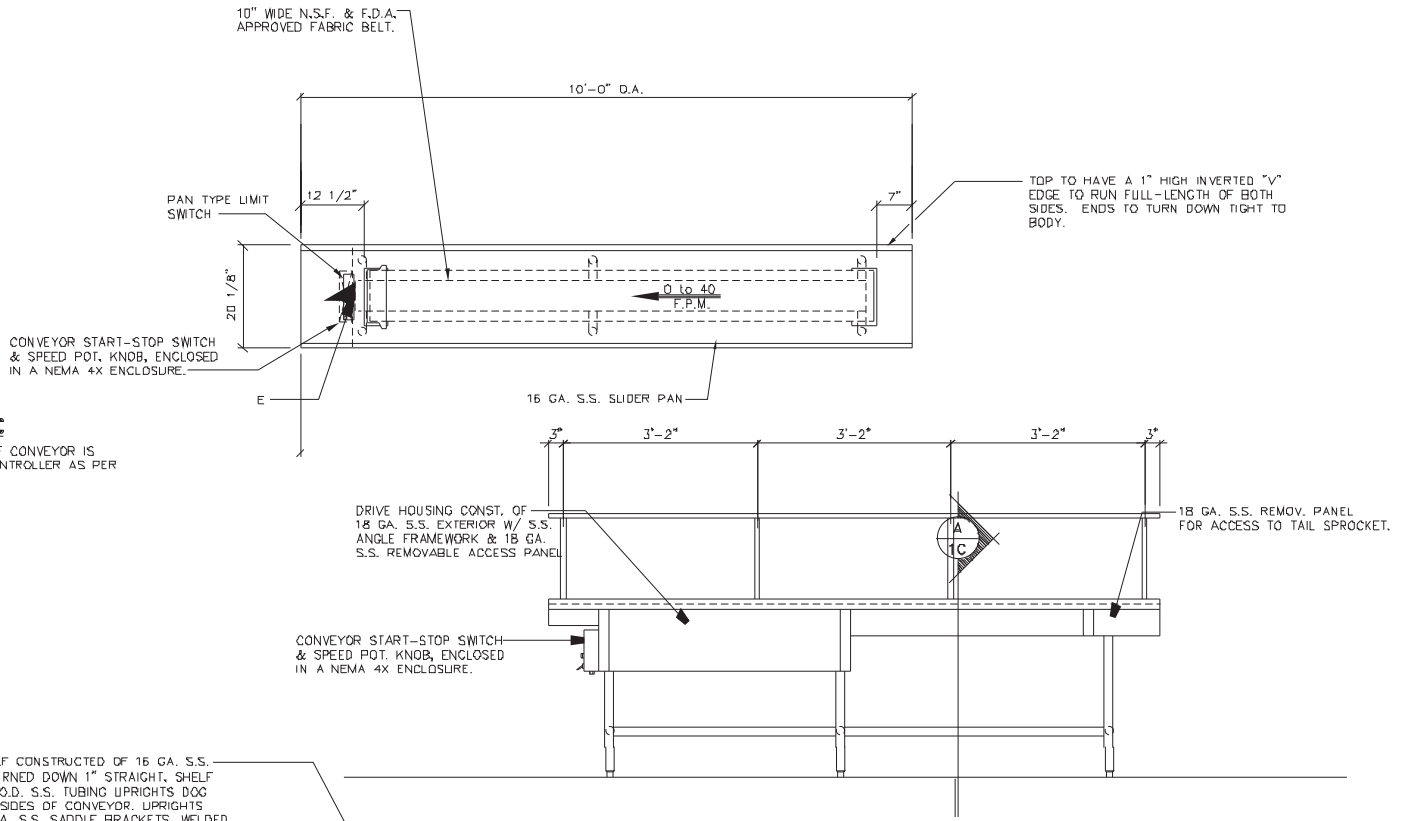

NOTE:

DIRECTION OF CONVEYOR IS TOWARDS CONTROLLER AS PER DRAWING.

ELEVATION VIEW

SCALE: 3/4"=1'-0"

ONE (1) OVER SHELF CONSTRUCTED OF 16 GA. S.S. WITH ALL EDGES TURNED DOWN 1" STRAIGHT, SHELF SUPPORTED ON 1" O.D. S.S. TUBING UPRIGHTS DOG LEGGED OUT OVER SIDES OF CONVEYOR. UPRIGHTS ATTACHED TO 14 GA. S.S. SADDLE BRACKETS, WELDED TO TUBES, LAPPED OVER INVERTED "V" EDGE OF CONVEYOR.

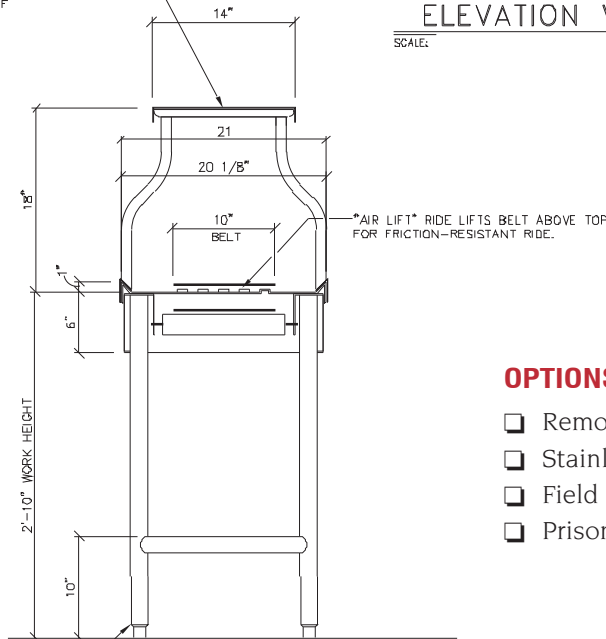

SECTION

SCALE: 1 1/2"=1'-0"

1 5/8" O.D. LEGS & CROSSRAILS W/ ADJ. BULLET SHAPE FEET

OPTIONS / ACCESSORIES

- Removable sections
- Stainless steel rollers
- Field joint
- Prison package

LIMITED WARRANTY: PIPER PRODUCTS warrants to the original purchaser parts and labor for a period of twelve (12) months from the date of purchase. See manufacturer's complete warranty for details.

It is our policy to build equipment which is design certified by companies that have been accredited at the Federal Level by the Occupational Safety and Health Agency (OSHA) and ANSI as a National Recognized Testing Laboratory. These companies include CSA International, Underwriters Laboratories, and the National Sanitation Foundation. However, a continuing program of product improvement makes it necessary to submit new models to the agencies as they are developed. Consequently, all models may not bear the appropriate labels at all times.

We reserve the right to change specifications and product design without notice. Such revisions do not entitle buyer to corresponding changes, improvements, additions or replacements for previously purchased equipment. Information is not for design purposes.

G-1-B SPEC

PIPER PRODUCTS
BUILT TO LAST
www.piperonline.net

300 S. 84th Avenue
 Wausau, WI 54401
 Phone: 800-544-3057
 Fax: 715-842-3125