

JOB _____ ITEM # _____ QTY # _____



2ATCA-SN
Shown with optional
silverware cylinders

MODEL NUMBER

- 2ATCA-SN-1014
- 2ATCA-SN-1216
- 2ATCA-SN-1418
- 2ATCA-SN-1520

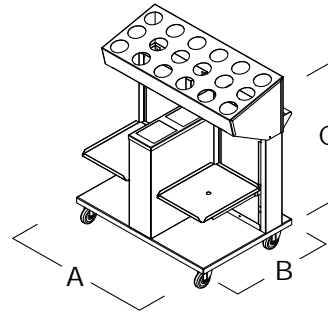

2ATCA-SN CANTILEVER STYLE, MOBILE TRAY AND SILVERWARE AND NAPKIN DISPENSER.

CAPACITY

Approx. 150 to 300 trays, 1000 paper napkins, 35-40 pieces of silverware in each cylinder.

FRAME AND BODY

The frame is constructed of all welded heavy gauge stainless steel. The body is stainless steel on all sides and top. The top is fitted with a stainless steel sloped overhead-type silverware dispenser, enclosed on all four sides and provided with eighteen openings for insertion of optional silverware cylinders. Two napkin dispensers are furnished, mounted in the center compartment between the tray dispensers (see specification on Page D-11). The front panel is removable for adjustment access.

DISPENSING MECHANISM

The tray carriers, constructed of all welded 16 ga. stainless steel, are each raised independently by a series of coil springs attached to the frame. Ball bearing guides and a single stainless steel aircraft type cable keep each carrier level in all directions, even with an unbalanced load. The cables run over pre-lubricated plated steel pulleys.

ADJUSTMENT

Adjustment for various tray weights is easily accomplished by removing the appropriate front panel, then engaging or disengaging individual springs as required.

CASTERS

The unit is mounted on four 4" diameter, extra heavy duty, swivel, casters.

MODELS / DIMENSIONS

		TRAY SIZE	A	B	C	Silverware Hole Qty
<input type="checkbox"/>	2ATCA-SN-1014	10x14	32-5/8	24-1/8	47	18
<input type="checkbox"/>	2ATCA-SN-1216	12-1/4 x 16-1/2	36-1/4	25-7/8	47	18
<input type="checkbox"/>	2ATCA-SN-1418	14x18	39-1/4	27-3/8	47	18
<input type="checkbox"/>	2ATCA-SN-1520	15-1/4 x 20-1/2	41-1/4	29-3/8	47	18

Shipping Weight: 500 lbs
Custom tray sizes available upon request.

OPTIONS / ACCESSORIES

Part #	Description
<input type="checkbox"/> WB	Two locking casters
<input type="checkbox"/> PB	Perimeter bumper
<input type="checkbox"/> B	Corner bumper
<input type="checkbox"/> Y4	Polyurethane 4" casters (set of 4)
<input type="checkbox"/> Y5	Polyurethane 5" casters (set of 4)
<input type="checkbox"/> 159-2701	Silverware Cylinder, plastic (each, 18 required)
<input type="checkbox"/> 011-3842	Silverware Cylinder, stainless steel (each, 18 required)
<input type="checkbox"/> TDNM	Napkin Dispenser, folded napkin 5" x 6-5/8"
<input type="checkbox"/> I (for carts)	Silverware, identity labels, (knives, forks, t-spoons)