

JOB _____ ITEM # _____ QTY # _____

MODEL NUMBER

FTDI



Frost Top Drop In shown
in a Piper Elite unit

Pipers innovative "Frost Top Units" are ideal for parfaits, pastries, gelatins and a variety of other dessert and salad dishes. These units combine excellent display and appeal with easy, efficient cooling.

STANDARD FEATURES

- ◆ 14-gauge stainless steel top with a feathered down edge on all sides
- ◆ Top has raised one-piece 14-gauge cold plate with drip trough on all sides, 1/2" drain and valve on one end of trough.
- ◆ A 3/4" drain is built into the bottom of the well to the right from the operator's side
- ◆ Uses environmentally friendly 134A refrigerant

ELECTRICAL

- ◆ 120 volts single-phase, 6.3 amps
- ◆ On/Off switch and pilot light are supplied in a remote mounted control box which is factory connected to the main control box via flexible conduit. Mounting this box requires a 5-5/8" W x 6-1/4" H cut-out opening in operator side of cabinet

REFRIGERATION SYSTEM

- ◆ 1/3 horsepower fan cooled condensing unit with an expansion valve and fin and tube evaporator coil.
- ◆ Environmentally safe 134A refrigerant
- ◆ Copper tubing refrigerant coils attached to the bottom of the cold plate and fully insulated.

WARRANTY

- ◆ One year parts and labor. Warranty is detailed on inside front cover of the price list.

SPEC D-8-B

PIPER PRODUCTS
BUILT TO LAST
www.piperonline.net

300 S. 84th Avenue
Wausau, WI 54401
Phone: 800-544-3057
Fax: 715-842-3125

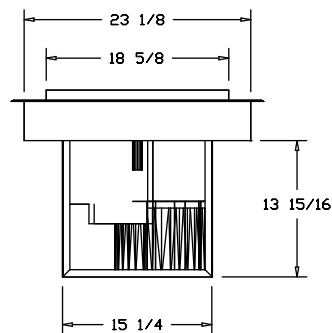
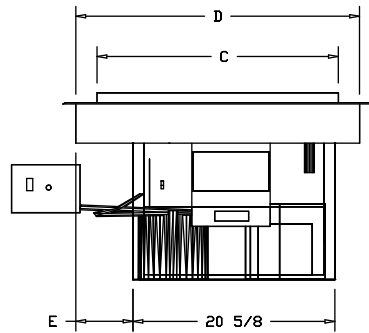
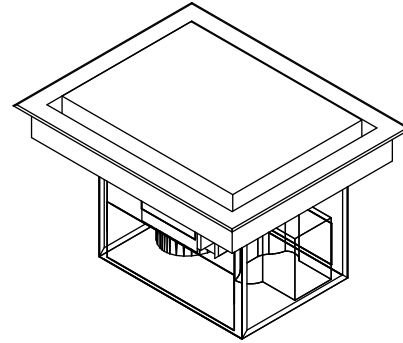
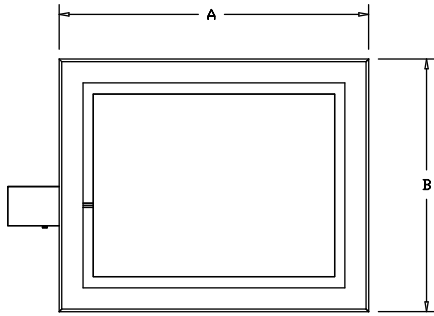

Model	A	B	C	D	E
2FT-DI	31-5/8"	25-5/8"	24-5/8"	29"	5-7/8"
3FT-DI	45-5/8"	25-5/8"	38-5/8"	43"	9-1/2"
4FT-DI	59-5/8"	25-5/8"	52-5/8"	57"	9-1/2"
5FT-DI	73-5/8"	25-5/8"	66-5/8"	71"	9-1/2"
6FT-DI	87-5/8"	25-5/8"	80-5/8"	85"	9-1/2"

D-8-B SPEC

PIPER PRODUCTS
BUILT TO LAST
www.piperonline.net

300 S. 84th Avenue
 Wausau, WI 54401
 Phone: 800-544-3057
 Fax: 715-842-3125

LIMITED WARRANTY: PIPER PRODUCTS warrants to the original purchaser parts and labor for a period of twelve (12) months from the date of purchase. See manufacturer's complete warranty for details.

It is our policy to build equipment which is design certified by companies that have been accredited at the Federal Level by the Occupational Safety and Health Agency (OSHA) and ANSI as a National Recognized Testing Laboratory. These companies include CSA International, Underwriters Laboratories, and the National Sanitation Foundation. However, a continuing program of product improvement makes it necessary to submit new models to the agencies as they are developed. Consequently, all models may not bear the appropriate labels at all times.

We reserve the right to change specifications and product design without notice. Such revisions do not entitle buyer to corresponding changes, improvements, additions or replacements for previously purchased equipment. Information is not for design purposes.