

JOB _____ ITEM # _____ QTY # _____

MODEL NUMBER

CC



CC-OD-B-T-L
B - Bottom-insulated w/o drain,
coved corner.

Piper's Bottom-mount Built-in Hot Food Wells are designed to maintain the serving temperature of prepared food during the serving period. Hot food wells may be used wet or dry.

ASSEMBLY STRUCTURE

- ◆ 20-gauge stainless steel seamless construction
- ◆ Deep drawn 12" x 20" x 6-3/8" wells
- ◆ CC series is a coved corner built-in designed as a bottom-mount to a fabricated die-stamped metal top
- ◆ The CC Series are available with or without drain, with a 1/2 NPT stainless steel welded drain in one end with a removable stainless steel screen
- ◆ Piper's hot food wells are either fully-insulated (4 sides and bottom) with a galvanized wrapper or bottom insulated only

CONTROLS

- ◆ Hot food wells are available with standard thermostat controls
- ◆ An optional infinite control is available
- ◆ Units come standard with 48" length capillary tubes
- ◆ Optional 72" length capillary tubes available
- ◆ See chart for easy ordering specifications

ELECTRICAL

- ◆ All units available in 120, 208/240 volts
- ◆ Well wattages can be ordered in 1000W, 1200W or 1600W elements
- ◆ Wire length or conduit on all units is standard at 48"
- ◆ Length of control wires or conduit (std. 48")
72" Option with infinite controls only.

WARRANTY

- ◆ One year parts and labor. Warranty is detailed on inside front cover of the price list.

QUICK CHECK

ORDERING INFORMATION

Part #	Description
<input type="checkbox"/> CC	Coved corner built-in
<input type="checkbox"/> OD	Without drain
<input type="checkbox"/> D	With drain
<input type="checkbox"/> A	Fully-insulated well
<input type="checkbox"/> B	Bottom-insulated only well
<input type="checkbox"/> T	Thermostat
<input type="checkbox"/> I	Infinite
<input type="checkbox"/> 12	Voltage 120
<input type="checkbox"/> L	Listed
<input type="checkbox"/> R	Recognized
<input type="checkbox"/> 20	Voltage 208
<input type="checkbox"/> 24	Voltage 240
<input type="checkbox"/> 10	Wattage 1000
<input type="checkbox"/> 12	Wattage 1200
<input type="checkbox"/> 16	Wattage 1600
<input type="checkbox"/> 72	72" Wiring Extension (Std. 48") With infinite control only.

Note: When ordering thermostatic or infinite controls, voltages of 208/240V have 1200/1600W respectively, and can be wired for either 208V or 240V power

To order units, simply check options listed above which will generate a specific order model for your customer.

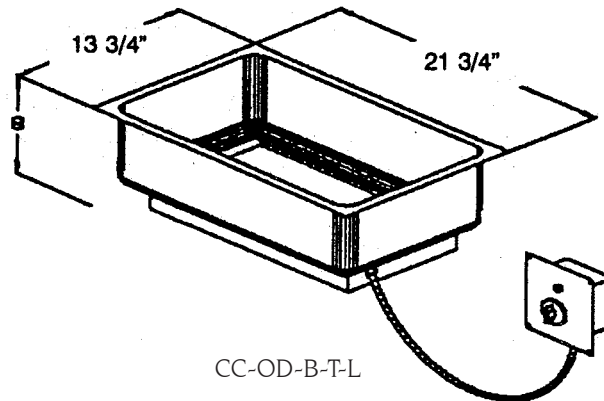
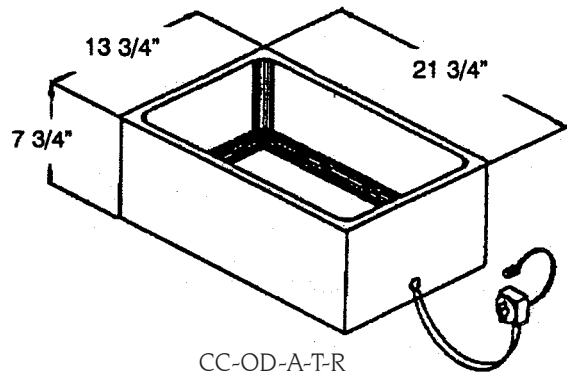

Model#	Length	Width	Inside Length	Inside Width	Overall Height	Inside Height	Bottom Indent	Top Cut Out L & W	Cutouts for Control Box H x W
CC-A	21-3/4"	13-3/4"	20-1/8"	12-1/8"	8-1/4"	6-3/8"	1/8"	20-1/16" x 12-1/16"	5-1/4" x 5"
CC-B	21-3/4"	13-3/4"	20-1/8"	12-1/8"	8"	6-3/8"	1/8"	20-1/16" x 12-1/16"	5-1/4" x 5"

ELECTRICAL SPECIFICATIONS

Volts	1000 Wattage	1200 Wattage	1600 Wattage
120 V	8.4 Amps	10.0 Amps	13.4 Amps
208/240	V 4.8/4.2 Amps	5.8/5.0 Amps	7.7/6.7 Amps

BID SPECIFICATIONS

Piper's Bottom-mount Built-in is constructed of heavyduty deep drawn seamless stainless steel 20 gauge thickness.

The unit can be bottom-insulated or fully-insulated and is designed to be built into a metal counter.

All drains are of stainless steel construction, 1/2 NPT fused welded to the bottom pan with a stainless steel removable screen.

Heating element is metal sheath tubular calrod construction, shaped in a double "U" configuration for even heat transfer to the well pan.

Element is mounted under the well pan and attached to an enclosed heat deflector which is fully insulated and shielded for best BTU transfer.

Deflector pan is installed to well pan with quick-removal threaded retainers.

D-2 SPEC

PIPER PRODUCTS
BUILT TO LAST
www.piperonline.net

300 S. 84th Avenue
Wausau, WI 54401
Phone: 800-544-3057
Fax: 715-842-3125

LIMITED WARRANTY: PIPER PRODUCTS warrants to the original purchaser parts and labor for a period of twelve (12) months from the date of purchase. See manufacturer's complete warranty for details.

It is our policy to build equipment which is design certified by companies that have been accredited at the Federal Level by the Occupational Safety and Health Agency (OSHA) and ANSI as a National Recognized Testing Laboratory. These companies include CSA International, Underwriters Laboratories, and the National Sanitation Foundation. However, a continuing program of product improvement makes it necessary to submit new models to the agencies as they are developed. Consequently, all models may not bear the appropriate labels at all times.

We reserve the right to change specifications and product design without notice. Such revisions do not entitle buyer to corresponding changes, improvements, additions or replacements for previously purchased equipment. Information is not for design purposes.