

JOB _____ ITEM # _____ QTY # _____



3-CM-SRTS-SKR
(Shown with options)

The Elite 500 Cold unit is available mechanically cooled (CM) or ice only (CI). The versatile modular design allows you to customize your cafeteria or buffet line-up, choosing only the options and accessories that you want and need. Elite 500 units are compatible and will interlock with other Elite 500 units. This allows the units to be disconnected for ease in cleaning.

STANDARD FEATURES

- ◆ 14-gauge stainless steel top with 1-1/2" turndown on all sides
- ◆ Top secured by four recessed bolts for easy access
- ◆ 14-gauge stainless steel legs fastened to 18-gauge stainless steel bottom shelf
- ◆ 20-gauge stainless steel end and front panels are attached to legs
- ◆ 20-gauge stainless steel fully welded 5" deep well with drain
- ◆ Well is enclosed with insulation on sides, end and bottom
- ◆ 1" drain with shut off valve shall exit operator's left side as standard. Drain valve is 3/4" FPT.
- ◆ Open control side for additional storage capacity on Elite units
- ◆ Sliding doors standard on Mechanical (CM) unit only.
- ◆ Louvered panels for ventilation of condensing unit on CM units
- ◆ End louver panel removable to access compressor on CM units
- ◆ 5" diameter swivel plate casters, 2 with brakes
- ◆ Interlocking mechanism is provided to interlock with other Elite 500 units

MODEL NUMBER

Mechanically Cooled

- 2-CM(502-2R-CW)
- 3-CM(502-3R-CW)
- 4-CM(502-4R-CW)
- 5-CM(502-5R-CW)
- 6-CM(502-6R-CW)

Ice pan

- 2-CI(502-2)
- 3-CI(502-3)
- 4-CI(502-4)
- 5-CI(502-5)
- 6-CI(502-6)

DIMENSIONS

- ◆ 2-CM(502-2R-CW) - 36"H x 28"D x 32"L
- ◆ 3-CM(502-3R-CW) - 36"H x 28"D x 46"L
- ◆ 4-CM(502-4R-CW) - 36"H x 28"D x 60"L
- ◆ 5-CM(502-5R-CW) - 36"H x 28"D x 74"L
- ◆ 6-CM(502-6R-CW) - 36"H x 28"D x 88"L
- ◆ 2-CI(502-2) - 36"H x 28"D x 32"L
- ◆ 3-CI(502-3) - 36"H x 28"D x 46"L
- ◆ 4-CI(502-4) - 36"H x 28"D x 60"L
- ◆ 5-CI(502-5) - 36"H x 28"D x 74"L
- ◆ 6-CI(502-6) - 36"H x 28"D x 88"L
- ◆ 36" height on all standard units
- ◆ 30" height is available on Petite Elite 500 units
- ◆ 28" width
- ◆ 32" to 88" length in 14" increments

ELECTRICAL - CM UNITS ONLY

- ◆ 120 volts single-phase
- ◆ Eight foot electrical cord with NEMA 5-15P plug
- ◆ On/Off switch and pilot light mounted on control panel of unit's operator side

REFRIGERATION SYSTEM - CM UNITS ONLY

- ◆ 1/3 horsepower compressor
- ◆ Fan-cooled condensing unit with an expansion valve pressure control switch
- ◆ Refrigerant coils shall be of copper tubing attached to the bottom of the well

COMMON OPTIONS

- ◆ **PIZZAZZ POWDER COATING IN LIEU OF STAINLESS STEEL**
- ◆ Tray slides
- ◆ Protector guards
- ◆ Hinged or sliding doors on CI units
- ◆ See reverse side for additional options

SPEC A-2

PIPER PRODUCTS
BUILT TO LAST
www.piperonline.net

300 S. 84th Avenue
Wausau, WI 54401
Phone: 800-544-3057
Fax: 715-842-3125

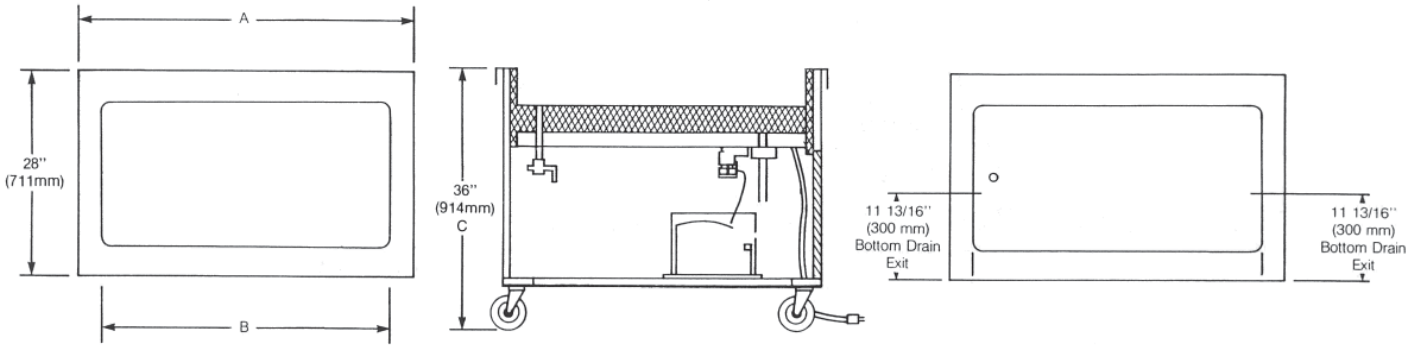

MECHANICALLY REFRIGERATED-ICE COOLED SPECIFICATIONS

Model#	12x20 Pan Capacity	A	B	C	*Amperage 120V	*NEMA Cap No.	Ship Wt. (lbs)	Model#	Ship Wt. (lbs)
2-CM(502-2R-CW)	2	32"	26 5/16"	36"	6.3	5-15P	325	2-CI(502-2)	225
3-CM(502-3R-CW)	3	46"	40"	36"	6.3	5-15P	365	3-CI(502-3)	265
4-CM(502-4R-CW)	4	60"	54"	36"	6.3	5-15P	405	4-CI(502-4)	305
5-CM(502-5R-CW)	5	74"	68"	36"	6.3	5-15P	445	5-CI(502-5)	345
6-CM(502-6R-CW)	6	88"	82"	36"	6.3	5-15P	490	6-CI(502-6)	385

*Amperage/NEMA plug type may vary with options.

DIMENSION ADDITIONS FOR OPTIONS

- ◆ Add 23-3/4" to height for buffet protector guard
- ◆ Add 14" to height for cafeteria protector guard
- ◆ Add 22-3/4" to height for double display shelf
- ◆ Add 8" to width for cutting board
- ◆ Add 12-3/4" to width for solid ribbed tray slide
- ◆ Add 12-1/2" to width for 3-bar tray slide

Note: Line-up drawing required when ordering false front, cashier stand or interconnected units.

OPTIONS / ACCESSORIES

Part #	Description
<input type="checkbox"/> PPC	PIZZAZZ POWDER COATING
<input type="checkbox"/> SCB	8" stainless steel cutting board, flush with top
<input type="checkbox"/> MCB	8" maple cutting board, flush with top
<input type="checkbox"/> SRTS	Solid 3-ribbed tray slide, 16-gauge stainless steel
<input type="checkbox"/> 3BTS	3-bar tray slide, 34" height
<input type="checkbox"/> MBS	18" maple end bread shelf; left, right - flush with top
<input type="checkbox"/> SBS	18" stainless steel end bread shelf; left, right - flush with top
<input type="checkbox"/> HD/SD	Hinged or sliding doors on Ice (CI) unit
<input type="checkbox"/> FRMAD	Formica laminate finish with doors
<input type="checkbox"/> CPG	Cafeteria protector guard (no heat or lights)
<input type="checkbox"/> CPGL	Cafeteria protector guard with incandescent lights
<input type="checkbox"/> CPGFL	Cafeteria protector guard with fluorescent lights
<input type="checkbox"/> CEG	Cafeteria end guards, right or left
<input type="checkbox"/> CDDL	Cafeteria double display (no heat or lights)
<input type="checkbox"/> CDD	Cafeteria double display with fluorescent lights
<input type="checkbox"/> BPG1	Buffet single side protector guard (no heat or lights)
<input type="checkbox"/> BPG1IL	Buffet single side protector guard with incandescent lights
<input type="checkbox"/> BPG1FL	Buffet single side protector guard with fluorescent lights

Part #	Description
<input type="checkbox"/> BPG	Buffet double side protector guard (no heat or lights)
<input type="checkbox"/> BPGIL	Buffet double side protector guard with incandescent lights
<input type="checkbox"/> BPGFL	Buffet double side protector guard with fluorescent lights
<input type="checkbox"/> BEG	Buffet end guards, right or left
<input type="checkbox"/> BDD	Buffet double display two-sided protector guard
<input type="checkbox"/> BPGC	Classic protector guards
<input type="checkbox"/> CDDC	Cafeteria Style Classic Double Display protector guards
<input type="checkbox"/> BPG1C	Buffet Style Classic Single Sided protector guards
<input type="checkbox"/> SCPGC	Cafeteria Style Classic Single protector guards
<input type="checkbox"/> SSL	Legs in lieu of casters
<input type="checkbox"/> DOUT	Duplex outlet (120V, 15 AMP)
<input type="checkbox"/> FB	False bottom
<input type="checkbox"/> SBT	Stainless steel salad bar template.
<input type="checkbox"/> UCR-1	Refrigerated storage base with doors and pan slides on units 60" or longer
<input type="checkbox"/> UCR-2	Refrigerated storage base with doors and pan slides on units 74" or longer
<input type="checkbox"/> SKR	Skirting

A-2 SPEC

PIPER PRODUCTS
BUILT TO LAST
www.piperonline.net

300 S. 84th Avenue
Wausau, WI 54401
Phone: 800-544-3057
Fax: 715-842-3125

LIMITED WARRANTY: PIPER PRODUCTS warrants to the original purchaser parts and labor for a period of twelve (12) months from the date of purchase. See manufacturer's complete warranty for details.

It is our policy to build equipment which is design certified by companies that have been accredited at the Federal Level by the Occupational Safety and Health Agency (OSHA) and ANSI as a National Recognized Testing Laboratory. These companies include CSA International, Underwriters Laboratories, and the National Sanitation Foundation. However, a continuing program of product improvement makes it necessary to submit new models to the agencies as they are developed. Consequently, all models may not bear the appropriate labels at all times.

We reserve the right to change specifications and product design without notice. Such revisions do not entitle buyer to corresponding changes, improvements, additions or replacements for previously purchased equipment. Information is not for design purposes.