

Assembly Instructions

Before you begin...

- Read directions completely to familiarize yourself with the procedure.
- Find a large, level area.
- You will need 2 7/16" wrenches or 2 adjustable wrenches (or 1 of each).
- Approximate assembly time is 10-15 minutes.

Parts List

- 2 - Side Assemblies (A)
- 4 - Cross braces (B)
- 2 - 1/2" Diam. Tie Bars (C)
- 4 - 5" Casters (D)
- 24 - Bolts (1/4-20 x 1-1/2")
- 20 - Nuts (1/4-20)

1

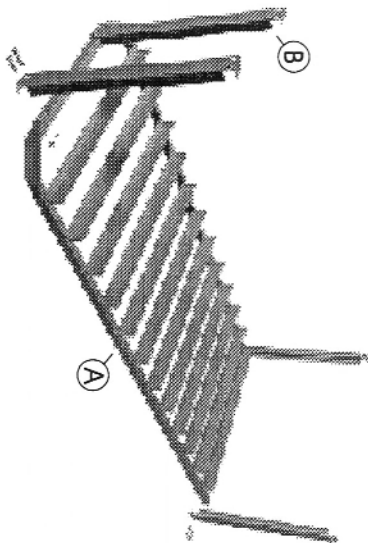

Lay one side assembly (A) on floor. Attach the four cross braces (B) as shown using 2 bolts and 2 nuts each. Lightly tighten.

2

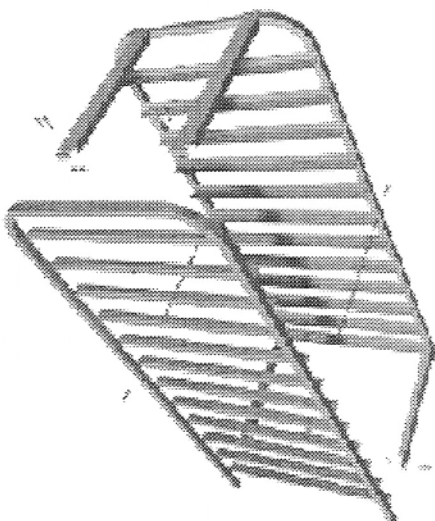

After attaching the braces, flip the rack on its side and slide the other side assembly (A) into the grooves on the cross braces. Insert the center tie bars (C) and tighten them on each side. Next, bolt the top cross braces and then the bottom cross braces to the side. Lightly tighten.

3

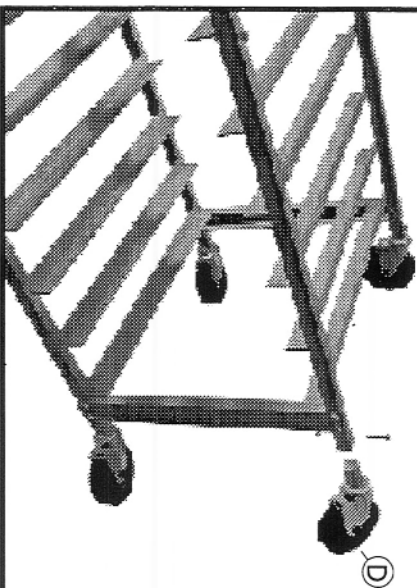

After all of the tie bars and cross braces are bolted into place, insert the casters (D) into the 1" tubing so the holes in the casters line up with the holes in the frame. Bolt tightly.

4

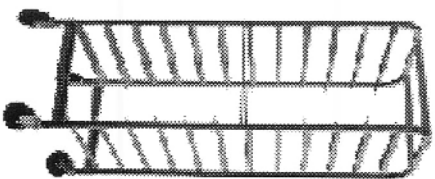

When the casters are tight, flip the rack upright and completely tighten the rest of the nuts. Your rack is now assembled.

Celebrations
Piper
PRODUCTS
40 years