

JOB \_\_\_\_\_ ITEM # \_\_\_\_\_ QTY # \_\_\_\_\_



3-HF Elite 500 shown with optional 3-bar tray slide and formica finish

The versatile modular design of the Elite 500 Serving System Hot Food units allows you to customize your cafeteria or a buffet line-up. Elite 500 units are compatible and will interlock with other Elite 500 units. This design allows the units to be disconnected for cleaning under the serving line. With Elite 500 you choose only the options and accessories that you want and need for your line-up.

Only Piper's equipment has the advantage of **FoodSafe** technology and certification. This ensures that your food is kept "out of the **Danger-Zone.**" Food spoilage occurs mainly because of rapidly accelerated bacteriological activity within the 40F-140F "**Danger Zone.**"

With **FoodSafe** hot food stays above 140F longer and cold food is kept below 40F. Both are key factors in HACCP compliance and the fight against foodborne pathogens.

### STANDARD FEATURES

- ◆ 14-gauge stainless steel top with 1-1/2" turndown on all sides
- ◆ Top secured by four recessed bolts for easy access
- ◆ 14-gauge stainless steel legs fastened to
- ◆ 18-gauge stainless steel bottom shelf, open control side
- ◆ Open control side for additional storage capacity
- ◆ 20-gauge stainless steel end and front panels are attached to legs
- ◆ 20-gauge stainless steel bottom-mounted wells, 6-1/2" deep with coved corners
- ◆ 2" insulation on sides and between wells, 1-1/2" on bottom, 1" on the ends and 1/4" fiber frax all around
- ◆ 1000 watt tubular heating element for each well is individually and thermostatically controlled
- ◆ Wells can be run wet or dry
- ◆ 5" diameter swivel plate casters, 2 with brakes
- ◆ Interlocking mechanism is provided to interlock with other Elite 500 units.
- ◆ Drain valve exits operator's left side as standard. Drain valve is 3/4" FPT.

### MODEL NUMBER

- 2-HF (501-2)       5-HF (501-5)
- 3-HF (501-3)       6-HF (501-6)
- 4-HF (501-4)

### DIMENSIONS

- ◆ 2-HF (501-2) - 36"H x 28"D x 32"L
- ◆ 3-HF (501-3) - 36"H x 28"D x 46"L
- ◆ 4-HF (501-4) - 36"H x 28"D x 60"L
- ◆ 5-HF (501-5) - 36"H x 28"D x 74"L
- ◆ 6-HF (501-6) - 36"H x 28"D x 88"L
- ◆ 36" height on all standard units
- ◆ 30" height is available on Petite Elite 500 units
- ◆ 28" width
- ◆ 32" to 88" length in 14" increments

### ELECTRICAL

- ◆ Two, three and four well units are available 120 volts
- ◆ All units available in 208 or 240 volt, single-phase standard
- ◆ Eight foot electrical cord and plug
- ◆ Some options or accessories may not be available with certain voltages

### COMMON OPTIONS

- ◆ **PIZZAZZ POWDER COATING IN LIEU OF STAINLESS STEEL**
- ◆ Tray slides
- ◆ Protector guards
- ◆ Hinged or sliding doors
- ◆ Common drains and manifolds
- ◆ See reverse side for additional options

### WARRANTY

One year parts and labor. Warranty is detailed on inside front cover of the price list.

**SPEC A-1**

**PIPER PRODUCTS**  
**BUILT TO LAST**  
[www.piperonline.net](http://www.piperonline.net)

300 S. 84th Avenue  
 Wausau, WI 54401  
 Phone: 800-544-3057  
 Fax: 715-842-3125

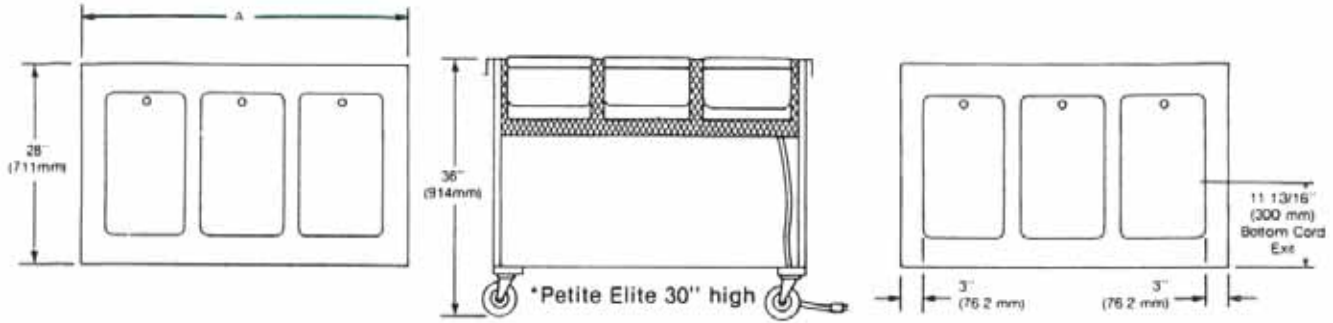

Model#	# of Wells	A	Watts	120V	Amps 208V	240V	NEMA Cap Number			Ship Wt. (lbs)
							120V	208V	240V	
2-HF (501-2)	2	32"	2000	16.7	9.6	8.3	5-30P	6-15P	6-15P	300
3-HF (501-3)	3	46"	3000	25.0	14.4	12.5	5-50P	6-15P	6-15P	310
4-HF (501-4)	4	60"	4000	33.3	19.2	16.7	5-50P	6-30P	6-30P	335
5-HF (501-5)	5	74"	5000	N/A	24.0	20.8	N/A	6-30P	6-30P	375
6-HF (501-6)	6	88"	6000	N/A	28.8	25.0	N/A	6-50P	6-50P	400

## DIMENSION ADDITIONS FOR OPTIONS

- ◆ Add 23-3/4" to height for buffet protector guard
- ◆ Add 14" to height for cafeteria protector guard
- ◆ Add 22-3/4" to height for double display shelf
- ◆ Add 8" to width for cutting board
- ◆ Add 12-3/4" to width for solid ribbed tray slide
- ◆ Add 12-1/2" to width for 3-bar tray slide

Note: Line-up drawing required when ordering false front, cashier stand or interconnected units.

Spacing between wells is 2". Floor clearance of unit is 6-1/4". Clearance height of open under storage is 17-3/4". Open under storage widths are 22-3/16", 36-3/16", 50-3/16", 64-3/16", and 78-3/16".

Part #	Description
<input type="checkbox"/> PPC	PIZZAZZ POWDER COATING
<input type="checkbox"/> SCB	8" stainless steel cutting board, flush with top
<input type="checkbox"/> MCB	8" maple cutting board, flush with top
<input type="checkbox"/> SRTS	Solid 3-ribbed tray slide, 16-gauge stainless steel
<input type="checkbox"/> 3BTS	3-bar tray slide
<input type="checkbox"/> MBS	18" maple end bread shelf; left, right - flush with top
<input type="checkbox"/> SBS	18" stainless steel end bread shelf; left, right - flush with top
<input type="checkbox"/> HD	Hinged doors with solid bottom
<input type="checkbox"/> SD	Sliding doors with solid bottom
<input type="checkbox"/> DRN	Common drains and manifold
<input type="checkbox"/> CPG	Cafeteria protector guard (no heat or lights)
<input type="checkbox"/> CPGL	Cafeteria protector guard with incandescent lights
<input type="checkbox"/> CPGFL	Cafeteria protector guard with fluorescent lights
<input type="checkbox"/> CEG	Cafeteria end guards, right or left
<input type="checkbox"/> INT	Intermediate shelf

Part #	Description
<input type="checkbox"/> FPB	Full perimeter bumper
<input type="checkbox"/> BPG1	Buffet single side protector guard (no heat or lights)
<input type="checkbox"/> BPG1IL	Buffet single side protector guard with incandescent lights
<input type="checkbox"/> BPG1FL	Buffet single side protector guard with fluorescent lights
<input type="checkbox"/> BEG	Buffet end guards, right or left
<input type="checkbox"/> BDD	Buffet double display two-sided protector guard
<input type="checkbox"/> BPGC	Classic protector guards
<input type="checkbox"/> CPGC	Cafeteria Style Classic Single protector guard
<input type="checkbox"/> BPG1C	Buffet Style Classic Single Sided protector guard
<input type="checkbox"/> SCPGC	Cafeteria Style Classic Single protector guards
<input type="checkbox"/> SSL	Legs in lieu of casters
<input type="checkbox"/> DOUT	Duplex outlet (120V, 15 AMP)
<input type="checkbox"/> FRMA	Formica laminate finish
<input type="checkbox"/> FLP	Filler Strips
<input type="checkbox"/> FF	Fill Faucet
<input type="checkbox"/> SKR	Skirting

## A-1 SPEC

**PIPER PRODUCTS**  
 BUILT TO LAST  
[www.piperonline.net](http://www.piperonline.net)

300 S. 84th Avenue  
 Wausau, WI 54401  
 Phone: 800-544-3057  
 Fax: 715-842-3125

**LIMITED WARRANTY:** PIPER PRODUCTS warrants to the original purchaser parts and labor for a period of twelve (12) months from the date of purchase. See manufacturer's complete warranty for details.

It is our policy to build equipment which is design certified by companies that have been accredited at the Federal Level by the Occupational Safety and Health Agency (OSHA) and ANSI as a National Recognized Testing Laboratory. These companies include CSA International, Underwriters Laboratories, and the National Sanitation Foundation. However, a continuing program of product improvement makes it necessary to submit new models to the agencies as they are developed. Consequently, all models may not bear the appropriate labels at all times.

We reserve the right to change specifications and product design without notice. Such revisions do not entitle buyer to corresponding changes, improvements, additions or replacements for previously purchased equipment. Information is not for design purposes.